



Milk separator NRSDH-30.

Introduction

NRSDH-30 Milk separator is used in the skim milk, cream, butter, casein, cheese production, anhydrous butter production process (centrifuge concentrate), and removal of foreign impurities in the milk (clarification). Similar products can also be used for clarification and purification.

All the parts that may contact the product are made of Stainless-Steel Grade 316. The power drive adopts the fluid clutch, transferring power by use of fluids in a reliable manner, whilst preventing overloading. The bearings used in the Sepak Industries Separators are SKF from Sweden.

The separator is controlled by a PLC automatic control system, with automatic de-slugging function which is controlled by adjustable timer.

The sealed water (7) is pumped into the sealing chamber (6), rising the sliding piston (4), and the solid ejection outlet (3) is shut down. Then the milk being processed is fed into the bowl from feeding pipe (1), under the effects of centrifugal force, the solids of heavier density is collected on the bowl wall, when the set timer is reached, the opening water (8) is pumped into the opening chamber (6), activating the sliding piston (5) to open the solid ejection outlet (3), impurities are removed from the bowl. The lighter liquid (cream) flows along the inner side of the discs into the passage of the upper distributor, the cream is discharged from the machine by the lower centripetal pump (8). The heavier liquid (skim milk) flows along the other passage, discharging from the machine by the upper centripetal pump (2). The automatic desludging allows continuous operation of the Milk Separator for the whole shift. The Separator is suitable for CIP.

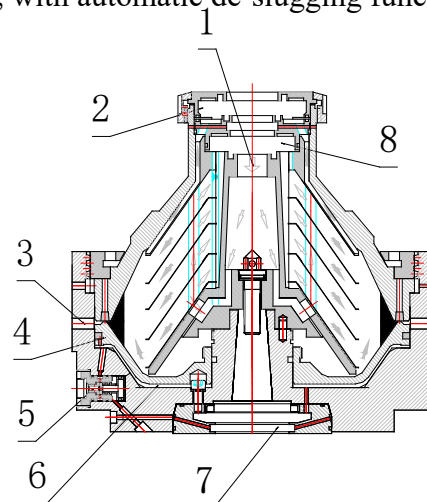

Technical data

Bowl diameter	mm	400	Bowl speed	r/min	6500
Flow rate	L/h	3000	Separation factor		9120
Cream output	Centripetal pump		Skim milk output	Centripetal pump	
Desludging	PLC controlled		Output pressure	MPa	0.3
Temperature	°C	35~55	Fat in skim milk	0.015~0.04%	
Power	KW	7.5KW	Dimension(L*W*H)	mm	1100*650*1550
Net height	Kg	680	Gross height	Kg	780